

BILLET DRIVER FLOORBOARD KIT



P/N 2882865-XXX, 2883021-XXX

APPLICATION

Verify accessory fitment at www.indianmotorcycle.com.

BEFORE YOU BEGIN

Read these instructions and check to be sure all parts and tools are accounted for. Please retain these installation instructions for future reference and parts ordering information.

KIT CONTENTS

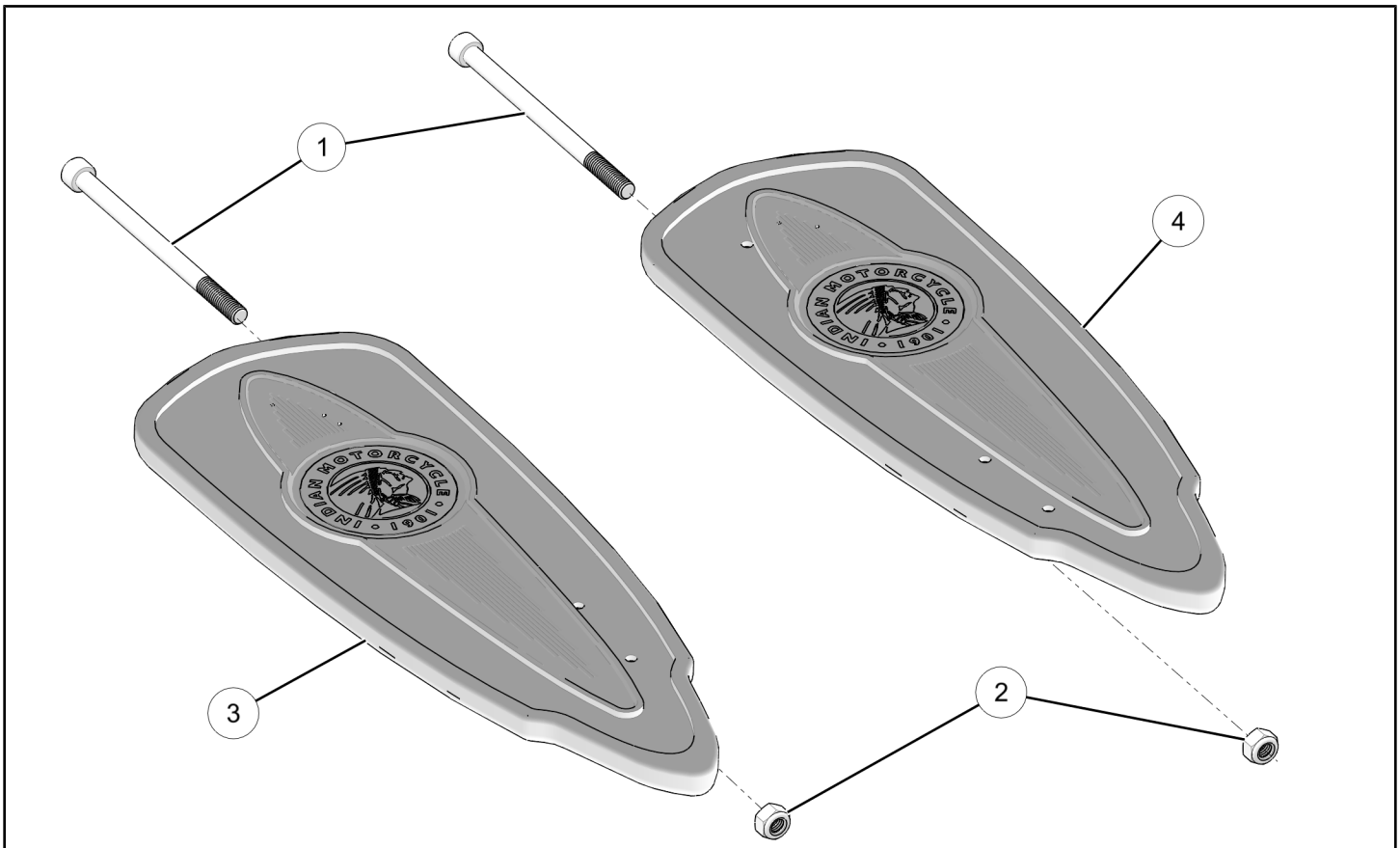

NOTICE

XXX = Indian Motorcycle® color code (For example: 266 = Black)

REF	QTY	PART DESCRIPTION	PART NUMBER
1	2	Bolt, Socket Head, M8 X 1.25 X 120	7520699
2	2	Nut, Nylon Locking, M8 X 1.25	7547673
3	1	Floorboard, Driver, Ness, 16, LH, (Kit P/N 2883021) Floorboard, Driver, Ness, 16, LH, (Kit P/N 2882865)	5141513-XXX 5141379-XXX
4	1	Floorboard, Driver, Ness, 16, RH, (Kit P/N 2883021) Floorboard, Driver, Ness, 16, RH, (Kit P/N 2882865)	5141514-XXX 5141378-XXX

TOOLS REQUIRED

- Safety Glasses
- Socket Set, Hex Bit, Metric
- Socket Set, Metric
- Torque Wrench
- Wrench Set, Metric

IMPORTANT

Your Indian Motorcycle® Billet Driver Floorboard Kit is exclusively designed for your vehicle. Please read the installation instructions thoroughly before beginning. Installation is easier if the vehicle is clean and free of debris. For your safety, and to ensure a satisfactory installation, perform all installation steps correctly in the sequence shown.

INSTALLATION INSTRUCTIONS

GENERAL

1. Turn key or ignition switch to **OFF** position and remove key. If equipped with keyless fob, remove fob from proximity of vehicle.
2. Ensure motorcycle is parked on a flat surface, kickstand is fully extended, and vehicle is stable prior to installation.

REMOVAL

1. Remove bolt (A) and nut (B) from under floorboard and remove floorboard. Retain two spacers (C) for installation.

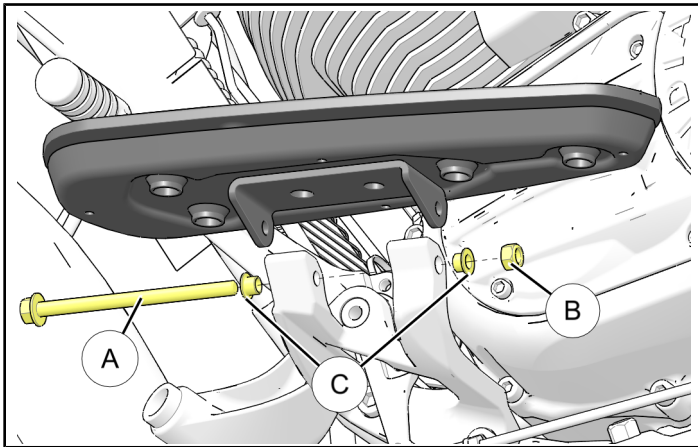

INSTALLATION

1. Ensure bushings (C) are in place and place new LH floorboard (3) on bracket. Install bolt (1) and nut (2). Torque fasteners to specification.

TORQUE

Floorboard Fasteners:
18 ft-lbs (24 N·m)

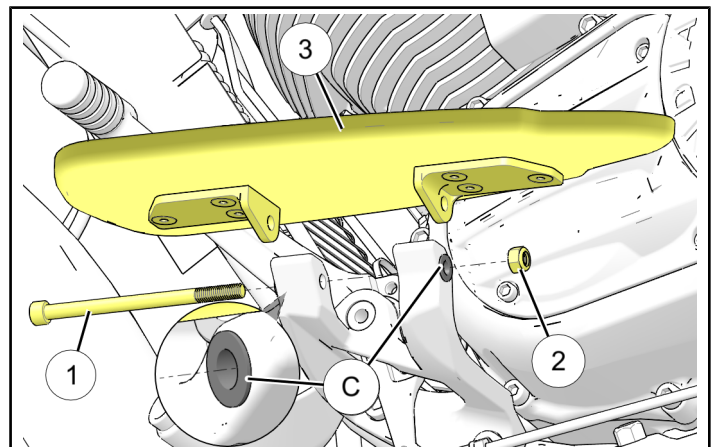

FEEDBACK FORM

A feedback form has been created for the installer to provide any comments, questions or concerns about the installation instructions. The form is viewable on mobile devices by scanning the QR code or by clicking [HERE](#) if viewing on a PC.

