

SCOUT LOCK & RIDE® FAIRING



P/N 2884116-XXX

BEFORE YOU BEGIN

Read these instructions and check to be sure all parts and tools are accounted for. Please retain these installation instructions for future reference and parts ordering information.

APPLICATION

Verify accessory fitment at www.indianmotorcycle.com.

REQUIRED SOLD SEPARATELY

Scout Bobber Models Only

Only parts for installation of the Indian Motorcycle® Scout Lock & Ride® Fairing are included. Prior installation of the following additional kits is also required (sold separately):

- Scout Headlight Relocation Kit, P/N 2884329

KIT CONTENTS

FAIRING KIT 2884116

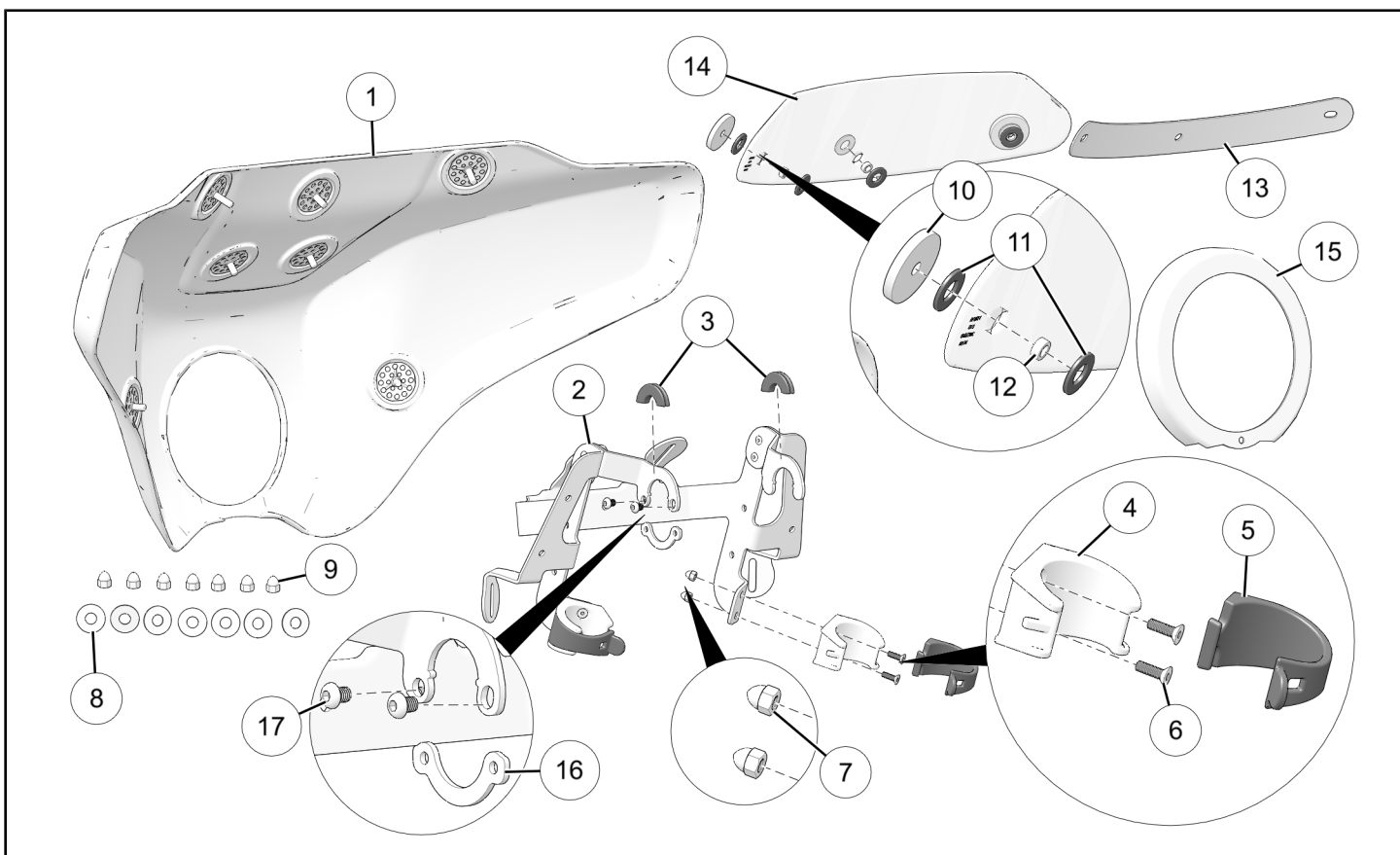

NOTE

XXX = Indian Motorcycle® color code (For example: 266 = Black)

REF	QTY	PART DESCRIPTION	P/N AVAILABLE SEPARATELY	AVAILABLE SERVICE KIT
1	1	Fairing, Scout	5456015	n/a
2	1	Assembly, Bracket, Fairing	1025042	n/a
3	2	Clamp, Under Bracket Lock Bumper, Rubber	-	2208185
4	2	Clamp, Lower Mount	-	2208185
5	2	Clamp, Rubber Support Strap	-	2208185
6	4	Screw, Counter Sunk, M5	-	2208185
7	4	Nut, Cap, M5	-	2208185
8	7	Washer, Steel, Black	-	2208185
9	7	Nut, Cap, Black, M6	-	2208185
10	2	Spacer, Aluminum, Black, M6	-	2208185
11	6	Washer, Rubber, Black	-	2208185
12	3	Spacer, Aluminum, M6	-	2208185
13	1	Bracket, Fairing, Windshield	-	2208185
14	1	Windshield, Fairing, Low	2689623	n/a
15	1	Ring, Headlight, Fairing	5417266	n/a
16	1	Clamp, Over Back Bracket	-	2208185
17	2	Screw, Over Clamp Bracket, Button Hex Head, M6	-	2208185

SCOUT® HEADLIGHT RELOCATION KIT 2884329

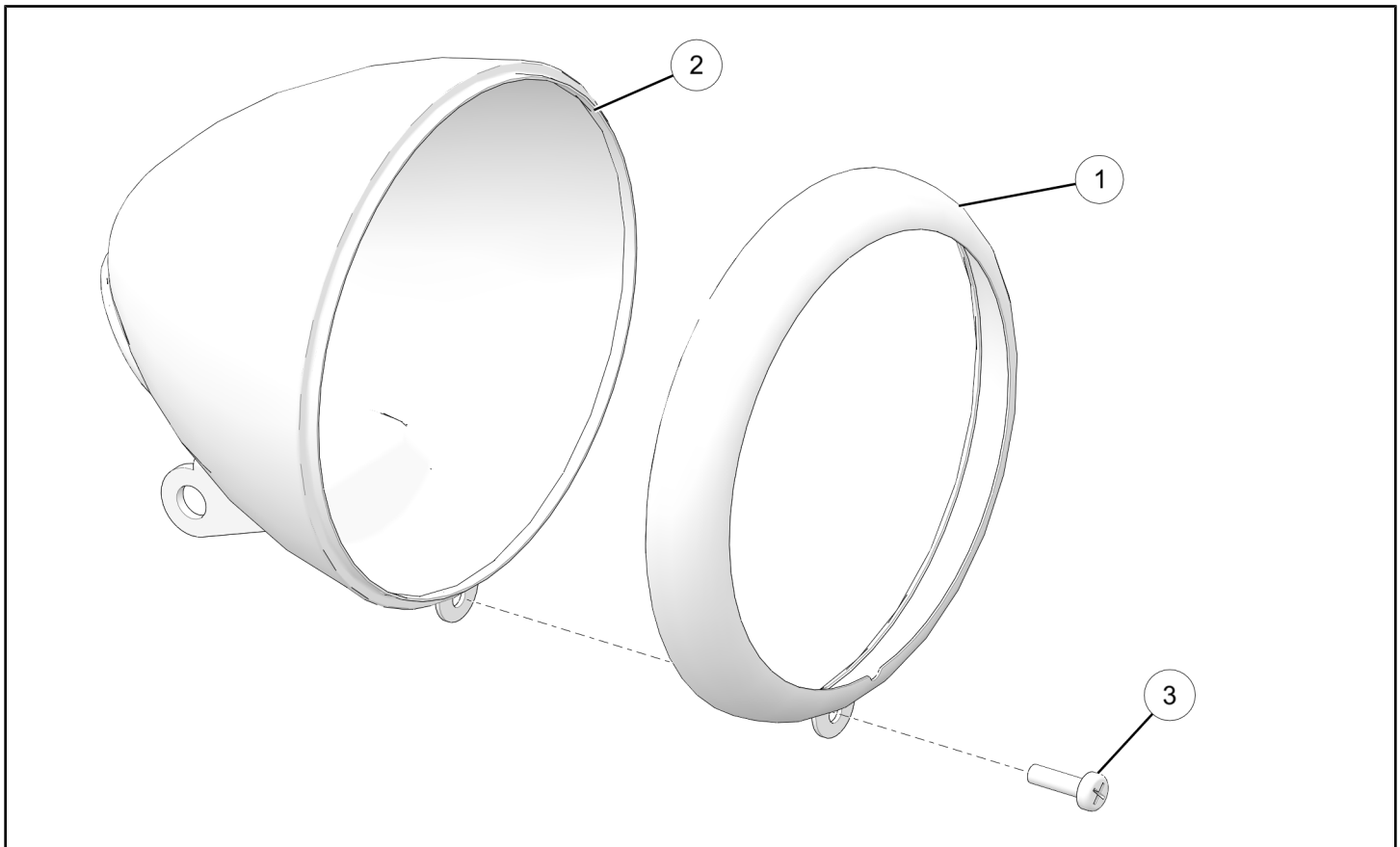

REF	QTY	PART DESCRIPTION	P/N AVAILABLE SEPARATELY
1	1	Assembly, Headlight Ring	2412601
2	1	Assembly, Headlight Bucket	-
3	1	Screw, Phillips, Pan Head, #12-24 X 0.75	7520084

TOOLS REQUIRED

- Safety Glasses
- Socket Set, Hex Bit, Metric
- Socket Set, Metric
- Torque Wrench
- Wrench Set, Metric

CONSUMABLES REQUIRED

- Loctite® Threadlocker Blue 242® (or comparable)

IMPORTANT

Your Indian Motorcycle® Scout Lock & Ride® Fairing is exclusively designed for your vehicle. Please read the installation instructions thoroughly before beginning. Installation is easier if the vehicle is clean and free of debris. For your safety, and to ensure a satisfactory installation, perform all installation steps correctly in the sequence shown.

INSTALLATION INSTRUCTIONS

VEHICLE PREPARATION

GENERAL

1. Turn key to **OFF** position and remove from vehicle.
2. Ensure motorcycle is parked on a flat surface, kickstand is fully extended, and vehicle is stable prior to installation.

ACCESSORY INSTALLATION

NOTE

Place a soft cloth over painted parts to protect finish during installation.

REMOVE NACELLE (BOBBER ONLY)

1. Remove six screws (A) from rear of headlight nacelle. Remove and set aside headlight nacelle and two brackets .

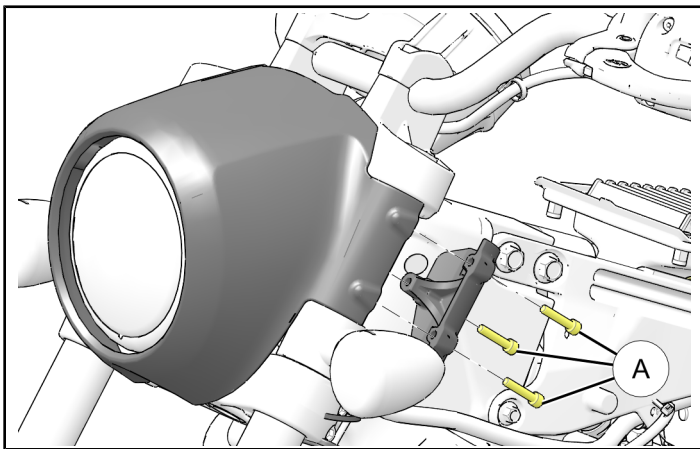

REMOVE HEADLIGHT

Indian® Scout® Models

1. Remove trim ring screw (A). Remove headlight (B) and trim ring (C).

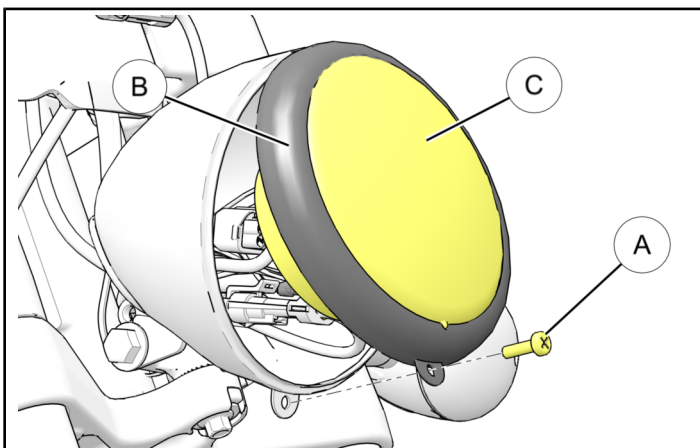

2. Skip to section: "Install Headlight Ring"

Indian® Scout® Bobber Models

1. Remove two trim ring screws (A). Remove headlight (B), trim ring (C) and rubber surround (D).

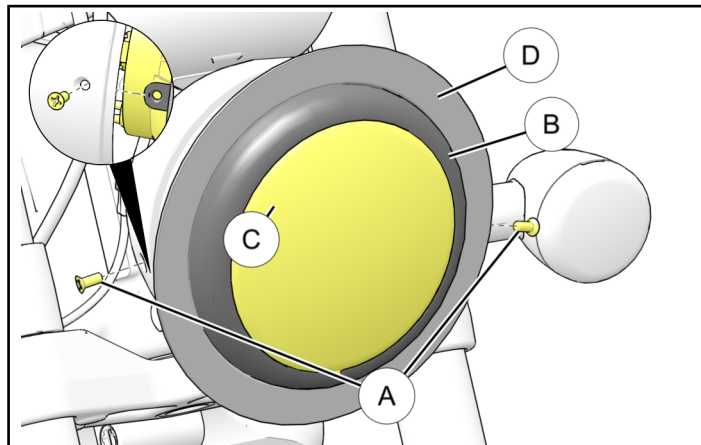

2. Remove and retain headlight housing nut (E) and bolt (F). Remove and discard housing (G).

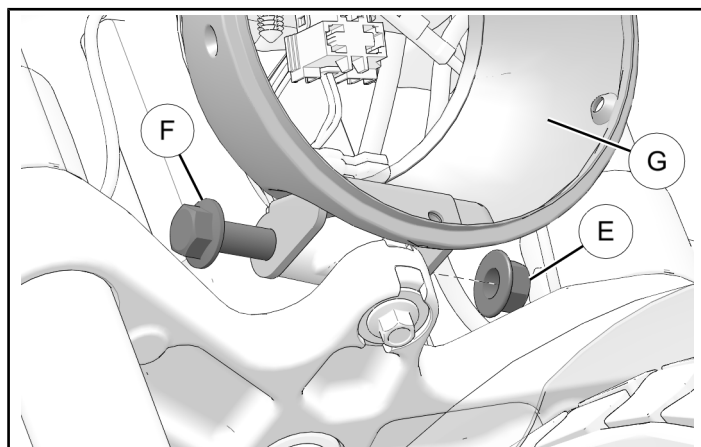

3. Remove and discard two screws (H) and bracket assembly (J).

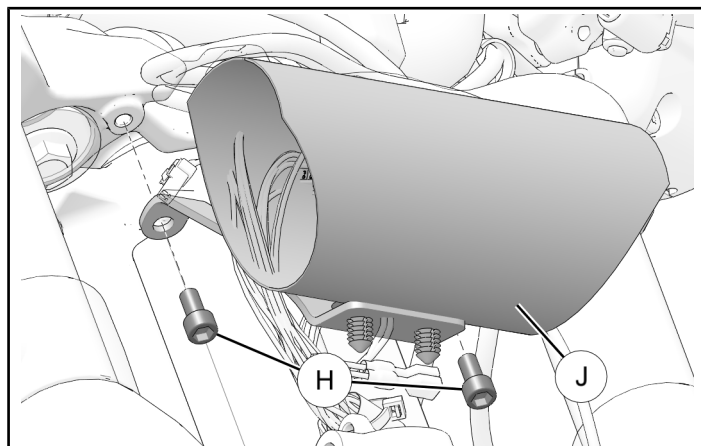

4. Install new headlight bucket ② (from kit PN 2884329) to stock location with retained bolt ⑥ and nut ⑤. Pull wiring for headlight into bucket. **DO NOT** torque fasteners at this time.

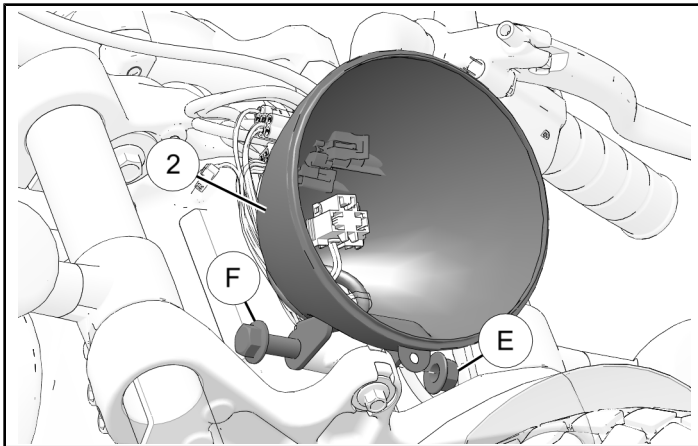

TRANSFER HEADLIGHT GLASS (BOBBER ONLY)

1. Set headlight on a non-scratching surface.
2. Remove and retain four spring clips ① from trim ring ② and separate headlight ③ from trim ring ②.

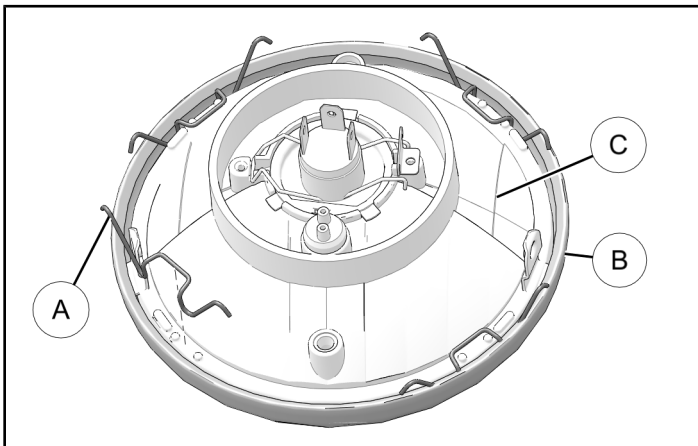

3. Insert headlight glass ③ into new trim ring ① (from kit PN 2884329). Secure glass with four retained spring clips ①.

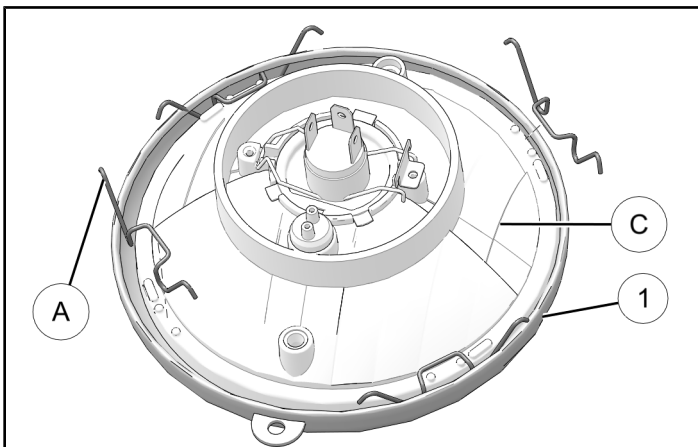

INSTALL HEADLIGHT RING

1. Install Fairing Headlight Ring ⑮ onto headlight bucket. Ensure hole in ring is aligned with screw hole on bottom edge of bucket.

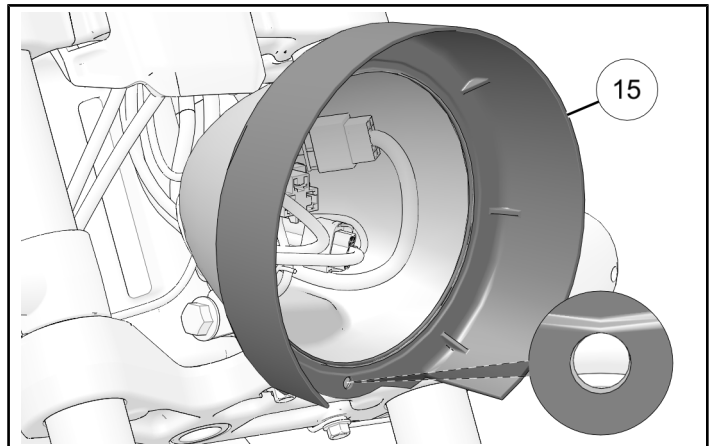

2. Install headlight glass assembly to headlight bucket. Retain with screw ③ or ④. Torque screw to specifications.

TORQUE

Headlight Bucket Trim Screw ③/④:
36 in-lbs (4 N·m)

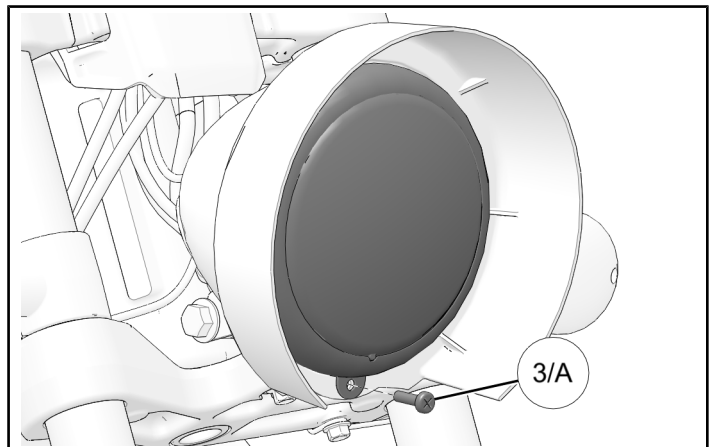

ASSEMBLE FAIRING

1. Remove and keep four nuts ⑨, four washers ⑧, and fairing bracket ② from fairing ①.

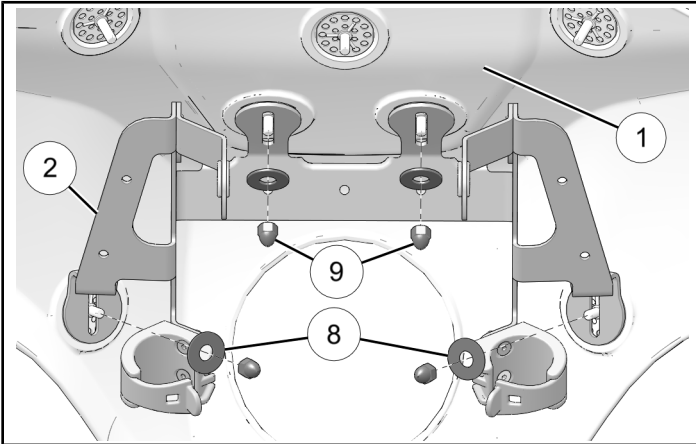

2. Insert two Rubber Support Straps ⑤ into two Lower Mount Clamps ④ and install clamps to Bracket ② with hook tabs facing inward as shown. Secure with two Cap Nuts ⑦ and Screws ⑥. Note proper orientation. Torque fasteners to specification.

TORQUE

Lower Mount Fasteners ⑥:
55 in-lbs (6 N·m)

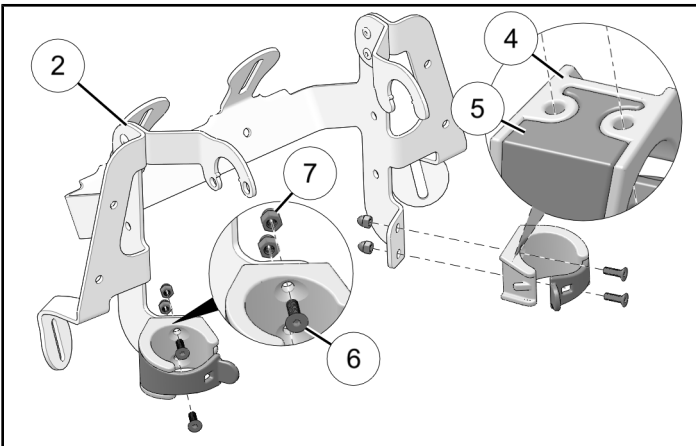

3. Insert two Rubber Bumpers ③ into openings in bracket ② as shown. Ensure bumpers are installed far enough so tabs can be seen as shown with arrows.

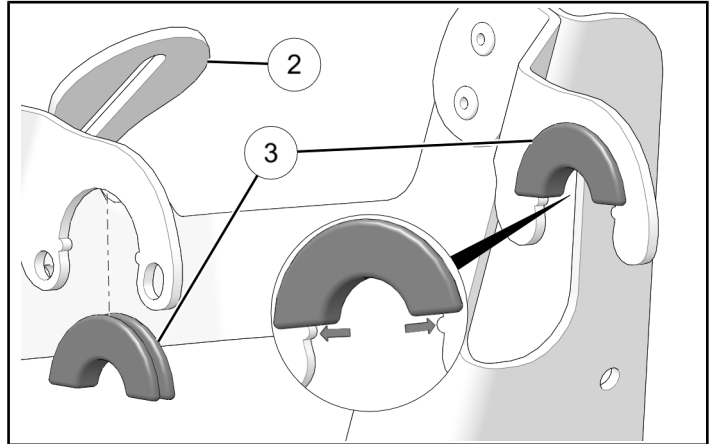

4. Apply thread locker to seven studs A on inside of fairing.

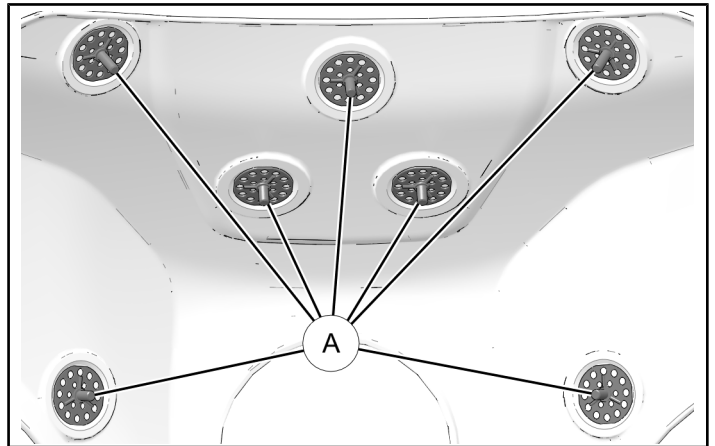

5. Install bracket ② to Fairing ① and secure with four washers ⑧ and four cap nuts ⑨. Torque cap nuts to specification.

TORQUE

Cap Nuts ⑨:
84 in-lbs (9.5 N·m)

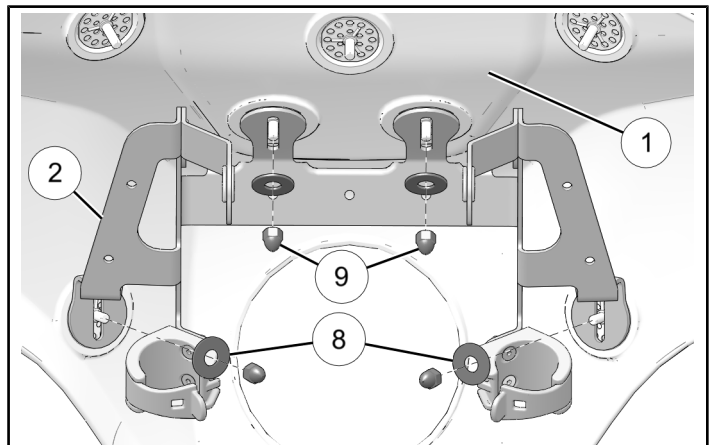

- Set two spacers ⑩ on outer windshield mount posts. Set three rubber washers ⑪ on windshield mount posts.

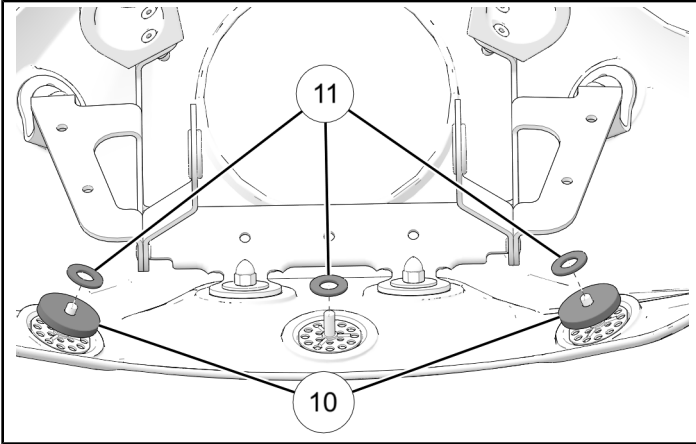

- Set windshield ⑭ in place on windshield mount posts. Insert three small spacers ⑫ onto posts followed by three rubber washers ⑪.

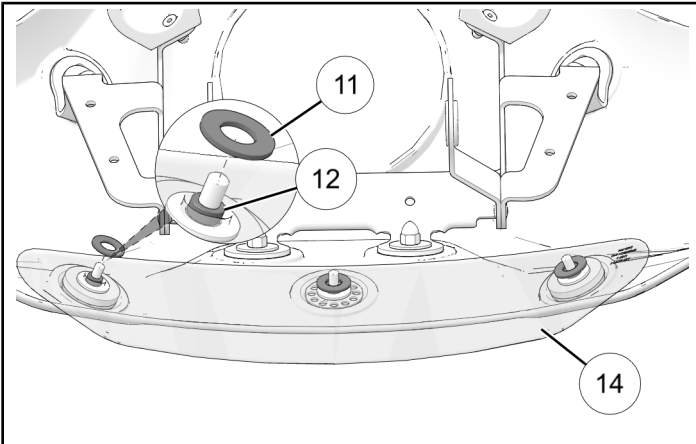

- Set Windshield Fairing Bracket ⑬ in place followed by three washers ⑧. Secure with three cap nuts ⑨. Torque cap nuts to specification.

TORQUE

Cap Nut ⑨:
84 in-lbs (9.5 N·m)

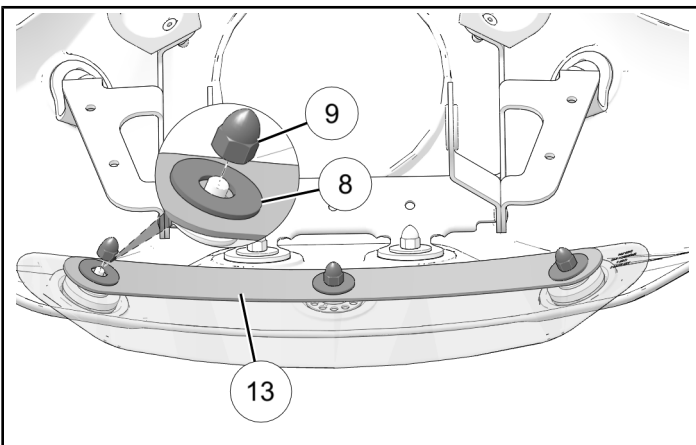

INSTALL FAIRING

- Place fairing bumpers ③ onto handlebars.

NOTE

Ensure brake line and clutch line are routed over top of fairing bracket as shown.

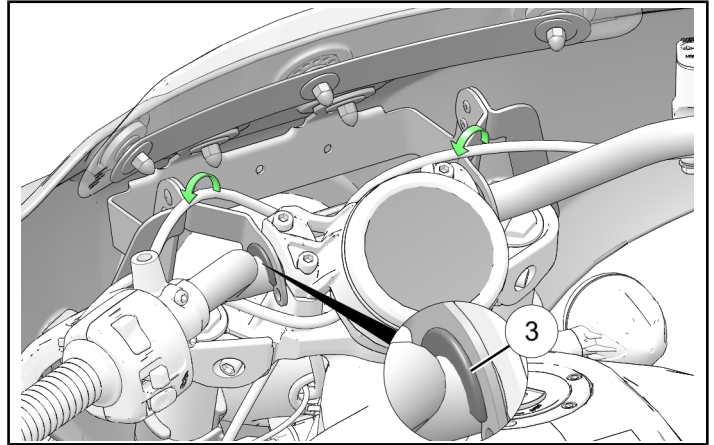

- Rotate fairing in place until lower mount brackets ④ are seated to fork.

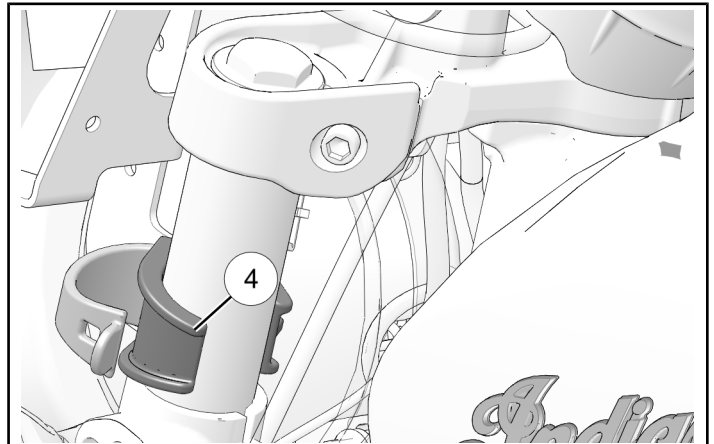

- Secure two rubber straps ⑤ to lower mount tabs (shown with arrow).

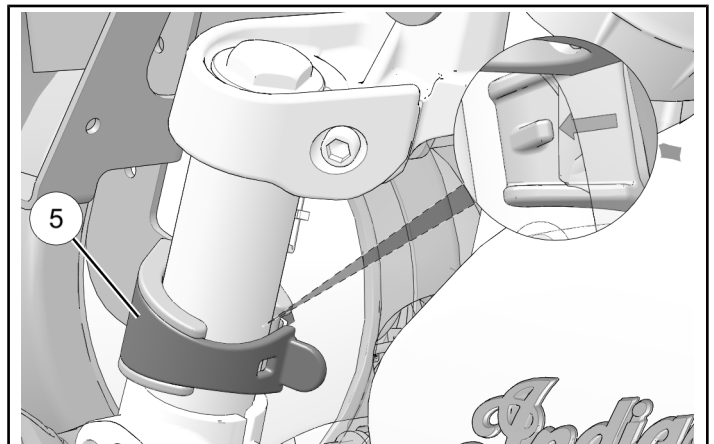

4. Press rubber surround in toward center of headlight as shown with arrows.

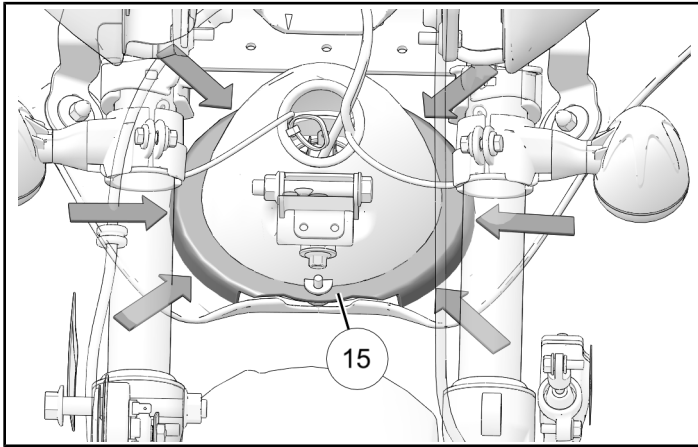

OPTIONAL ANTI-THEFT PROTECTION

1. For added theft protection, install locking clip ⑯ onto bracket, apply thread locker to threads of two screws ⑰ and secure with screws. Torque screws to specification.

TORQUE

Bracket Clamp Screw ⑰:
36 in-lbs (4 N·m)

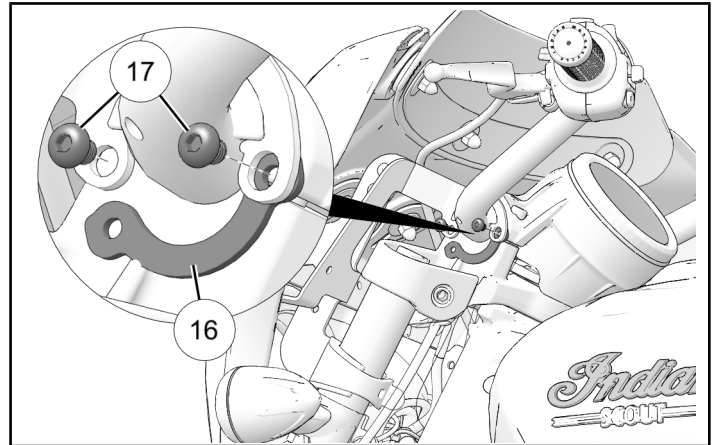

FEEDBACK FORM

A feedback form has been created for the installer to provide any comments, questions or concerns about the installation instructions. The form is viewable on mobile devices by scanning the QR code or by clicking [HERE](#) if viewing on a PC.

